



# AiPTS010X

## X-Bit Bidirectional Level-Shifting, Voltage-Level Translator

### Product Specification

**Specification Revision History:**

Version	Date	Description
2021-04-A1	2021-04	New
2023-02-A2	2023-02	Modify the content
2023-05-A3	2023-05	Update the package information
2023-11-A4	2023-11	Update the package information
2023-12-A5	2023-12	Add XSON8/QFN10 package information



## 1、General Description

The AiPTS010X is a X-bit, dual supply translating transceiver with auto direction sensing, that enables bidirectional voltage level translation. It features two 1-bit input-output ports (A and B), one output enable input (OE) and two supply pins ( $V_{CC(A)}$  and  $V_{CC(B)}$ ).  $V_{CC(A)}$  can be supplied at any voltage between 1.65V and 3.6V.  $V_{CC(B)}$  can be supplied at any voltage between 2.3V and 5.5V. This flexibility makes the device suitable for translating between any of the voltage nodes (1.8V, 2.5V, 3.3V and 5.0V). Pins A and OE are referenced to  $V_{CC(A)}$  and pin B is referenced to  $V_{CC(B)}$ . A LOW level at pin OE causes the outputs to assume a high-impedance OFF-state. This device is fully specified for partial power-down applications using  $I_{OFF}$ . The  $I_{OFF}$  circuitry disables the output, preventing the damaging backflow current through the device when it is powered down.

### Features:

- Wide supply voltage range:  
 $V_{CC(A)}$ : 1.65V to 3.6V  
 $V_{CC(B)}$ : 2.3V to 5.5V
- Maximum data rates:  
Push-pull: 50 Mbps  
Open-drain: 2 Mbps
- $I_{OFF}$  circuitry provides partial Power-down mode operation
- Inputs accept voltages up to 5.5V
- Specified from -40 to +105°C
- Package:  
AiPTS0101: SOT23-6/SOT363  
AiPTS0102: TSSOP8/VSSOP8/XSON8  
AiPTS0103: QFN10  
AiPTS0104: SOP14/TSSOP14  
AiPTS0108: TSSOP20

**Ordering Information:****Tube packing specifications:**

Part number	Packaging form	Marking code	Tube quantity	Boxed tube quantity	Boxed quantity	Notes
AiPTS0102 TA8.TB	TSSOP8	DAXX	100 PCS/tube	200 tube/box	20000 PCS/box	Dimensions of plastic enclosure: 3.0mm×3.0mm Pin spacing: 0.65mm
AiPTS0104 SA14.TB	SOP14	AiPTS0104	50 PCS/tube	200 tube/box	10000 PCS/box	Dimensions of plastic enclosure: 8.7mm×3.9mm Pin spacing: 1.27mm
AiPTS0104 TA14.TB	TSSOP14	AiPTS0104	96 PCS/tube	200 tube/box	19200 PCS/box	Dimensions of plastic enclosure: 5.0mm×4.4mm Pin spacing: 0.65mm
AiPTS0108 TA20.TB	TSSOP20	AiPTS0108	70 PCS/tube	200 tube/box	14000 PCS/box	Dimensions of plastic enclosure: 6.5mm×4.4mm Pin spacing: 0.65mm

**Reel packing specifications:**

Part number	Packaging form	Marking code	Reel quantity	Boxed reel quantity	Notes
AiPTS0101GB236.TR	SOT23-6	CZXX	3000 PCS/reel	30000 PCS/box	Dimensions of plastic enclosure: 2.9mm×1.6mm Pin spacing: 0.95mm
AiPTS0101GC363.TR	SOT363	CZXX	3000 PCS/reel	30000 PCS/box	Dimensions of plastic enclosure: 2.1mm×1.3mm Pin spacing: 0.65mm
AiPTS0102TA8.TR	TSSOP8	DAXX	3000 PCS/reel	3000 PCS/box	Dimensions of plastic enclosure: 3.0mm×3.0mm Pin spacing: 0.65mm
AiPTS0102YA8.TR	VSSOP8	DAXX	3000 PCS/reel	3000 PCS/box	Dimensions of plastic enclosure: 2.0mm×2.3mm Pin spacing: 0.50mm
AiPTS0102EB8.TR	XSON8	DAXX	5000 PCS/reel	25000 PCS/box	Dimensions of plastic enclosure: 1.35mm×1.00mm Pin spacing: 0.35mm
AiPTS0102QI10.TR	QFN10	DZXX	3000 PCS/reel	15000 PCS/box	Dimensions of plastic enclosure: 1.80mm×1.40mm Pin spacing: 0.40mm
AiPTS0104SA14.TR	SOP14	AiPTS0104	4000 PCS/reel	8000 PCS/box	Dimensions of plastic enclosure: 8.7mm×3.9mm Pin spacing: 1.27mm
AiPTS0104TA14.TR	TSSOP14	AiPTS0104	5000 PCS/reel	10000 PCS/box	Dimensions of plastic enclosure: 5.0mm×4.4mm Pin spacing: 0.65mm
AiPTS0108TA20.TR	TSSOP20	AiPTS0108	4000 PCS/reel	8000 PCS/box	Dimensions of plastic enclosure: 6.5mm×4.4mm Pin spacing: 0.65mm

Note 1: "XX" refers to variable content, meaning year and package batch serial number.

Note 2: If the physical information is inconsistent with the ordering information, please refer to the actual product.



## 2、Block Diagram And Pin Description

### 2.1、Block Diagram

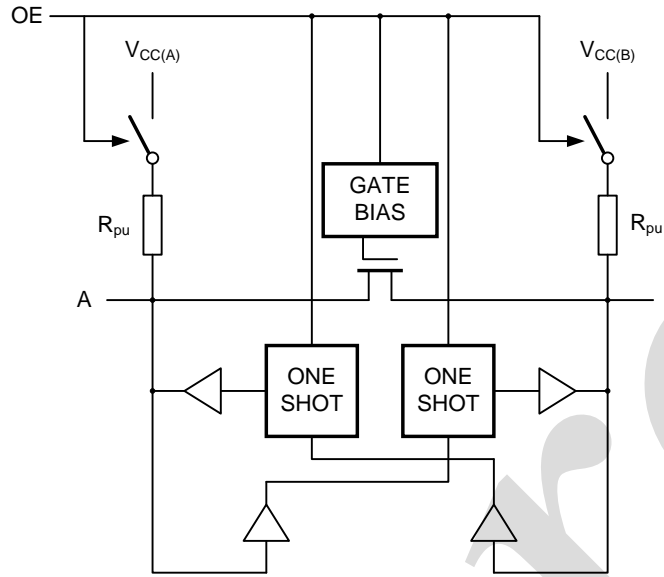

### 2.2、Pin Configurations

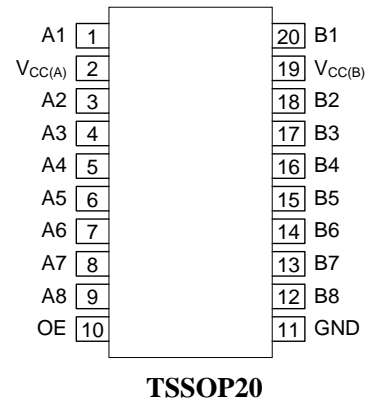
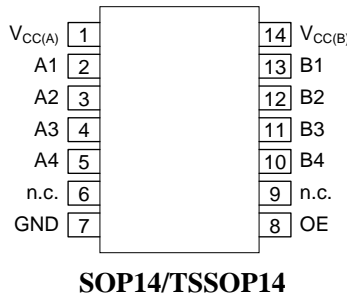
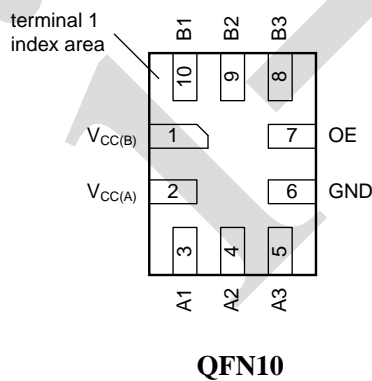
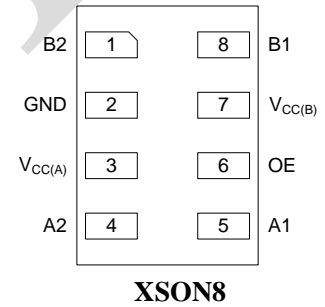
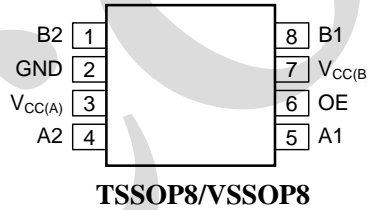
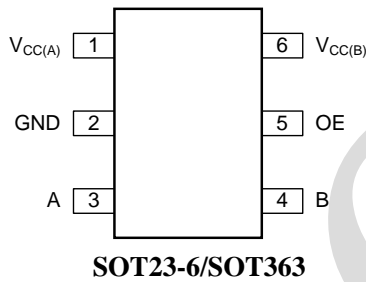



## 2.3、Pin Description

### 2.3.1、SOT23-6/SOT363

Pin No.	Pin Name	Description
1	V <sub>CC(A)</sub>	supply voltage A
2	GND	ground (0V)
3	A	data input or output (referenced to V <sub>CC(A)</sub> )
4	B	data input or output (referenced to V <sub>CC(B)</sub> )
5	OE	output enable input (active HIGH; referenced to V <sub>CC(A)</sub> )
6	V <sub>CC(B)</sub>	supply voltage B

### 2.3.2、TSSOP8/VSSOP8/XSON8

Pin No.	Pin Name	Description
1	B2	data input or output (referenced to V <sub>CC(B)</sub> )
2	GND	ground (0V)
3	V <sub>CC(A)</sub>	supply voltage A
4	A2	data input or output (referenced to V <sub>CC(A)</sub> )
5	A1	data input or output (referenced to V <sub>CC(A)</sub> )
6	OE	output enable input (active HIGH; referenced to V <sub>CC(A)</sub> )
7	V <sub>CC(B)</sub>	supply voltage B
8	B1	data input or output (referenced to V <sub>CC(B)</sub> )

### 2.3.3、QFN10

Pin No.	Pin Name	Description
1	V <sub>CC(B)</sub>	supply voltage B
2	V <sub>CC(A)</sub>	supply voltage A
3	A1	data input or output (referenced to V <sub>CC(A)</sub> )
4	A2	data input or output (referenced to V <sub>CC(A)</sub> )
5	A3	data input or output (referenced to V <sub>CC(A)</sub> )
6	GND	ground (0V)
7	OE	output enable input (active HIGH; referenced to V <sub>CC(A)</sub> )
8	B3	data input or output (referenced to V <sub>CC(B)</sub> )
9	B2	data input or output (referenced to V <sub>CC(B)</sub> )
10	B1	data input or output (referenced to V <sub>CC(B)</sub> )

### 2.3.4、SOP14/TSSOP14

Pin No.	Pin Name	Description
1	V <sub>CC(A)</sub>	supply voltage A
2	A1	data input or output (referenced to V <sub>CC(A)</sub> )
3	A2	data input or output (referenced to V <sub>CC(A)</sub> )
4	A3	data input or output (referenced to V <sub>CC(A)</sub> )
5	A4	data input or output (referenced to V <sub>CC(A)</sub> )
6	n.c.	not connected
7	GND	ground (0V)



8	OE	output enable input (active HIGH; referenced to $V_{CC(A)}$ )
9	n.c.	not connected
10	B4	data input or output (referenced to $V_{CC(B)}$ )
11	B3	data input or output (referenced to $V_{CC(B)}$ )
12	B2	data input or output (referenced to $V_{CC(B)}$ )
13	B1	data input or output (referenced to $V_{CC(B)}$ )
14	$V_{CC(B)}$	supply voltage B

### 2.3.5、TSSOP20

Pin No.	Pin Name	Description
1	A1	data input or output (referenced to $V_{CC(A)}$ )
2	$V_{CC(A)}$	supply voltage A
3	A2	data input or output (referenced to $V_{CC(A)}$ )
4	A3	data input or output (referenced to $V_{CC(A)}$ )
5	A4	data input or output (referenced to $V_{CC(A)}$ )
6	A5	data input or output (referenced to $V_{CC(A)}$ )
7	A6	data input or output (referenced to $V_{CC(A)}$ )
8	A7	data input or output (referenced to $V_{CC(A)}$ )
9	A8	data input or output (referenced to $V_{CC(A)}$ )
10	OE	output enable input (active HIGH; referenced to $V_{CC(A)}$ )
11	GND	ground (0V)
12	B8	data input or output (referenced to $V_{CC(B)}$ )
13	B7	data input or output (referenced to $V_{CC(B)}$ )
14	B6	data input or output (referenced to $V_{CC(B)}$ )
15	B5	data input or output (referenced to $V_{CC(B)}$ )
16	B4	data input or output (referenced to $V_{CC(B)}$ )
17	B3	data input or output (referenced to $V_{CC(B)}$ )
18	B2	data input or output (referenced to $V_{CC(B)}$ )
19	$V_{CC(B)}$	supply voltage B
20	B1	data input or output (referenced to $V_{CC(B)}$ )

### 2.4、Function table

Supply voltage		Input	Input/output	
$V_{CC(A)}$	$V_{CC(B)}$	OE	A	B
1.65V to 3.6V	2.3V to 5.5V	L	Z	Z
1.65V to 3.6V	2.3V to 5.5V	H	input or output	output or input
GND	2.3V to 5.5V	X	Z	Z
1.65V to 3.6V	GND	X	Z	Z

Note:

[1] H=HIGH voltage level; L=LOW voltage level; X=don't care; Z=high-impedance OFF-state.

[2]  $V_{CC(A)}$  must be less than or equal to  $V_{CC(B)}$ .



## 3、Electrical Parameter

### 3.1、Absolute Maximum Ratings

( $T_{amb}=25^{\circ}\text{C}$ , All voltage referenced to GND, unless otherwise specified)

Characteristic	Symbol	Conditions	Min.	Max.	Unit
supply voltage A	$V_{CC(A)}$	-	-0.5	+6.5	V
supply voltage B	$V_{CC(B)}$	-	-0.5	+6.5	V
input voltage	$V_I$	OE <sup>[1]</sup>	-0.5	+6.5	V
		A, B port; Power-down or 3-state mode <sup>[1]</sup>	-0.5	+6.5	V
		A, B port; Active mode <sup>[1][2][3]</sup>	-0.5	$V_{CCI}+0.5$	V
output voltage	$V_O$	A, B port; Power-down or 3-state mode <sup>[1]</sup>	-0.5	+6.5	V
		A, B port; Active mode <sup>[1][3][4]</sup>	-0.5	$V_{CCO}+0.5$	V
input clamping current	$I_{IK}$	$V_I < 0\text{V}$	-50	-	mA
output clamping current	$I_{OK}$	$V_O < 0\text{V}$	-50	-	mA
output current	$I_O$	$V_O=0\text{V}$ to $V_{CCO}$ <sup>[4]</sup>	-	$\pm 50$	mA
supply current	$I_{CC}$	$I_{CC(A)}$ or $I_{CC(B)}$	-	100	mA
ground current	$I_{GND}$	-	-100	-	mA
storage temperature	$T_{stg}$	-	-65	+150	$^{\circ}\text{C}$
total power dissipation	$P_{tot}$	-	-	500	mW
soldering temperature	$T_L$	10s	260		$^{\circ}\text{C}$

Note:

[1] The minimum input and minimum output voltage ratings may be exceeded if the input and output current ratings are observed.

[2]  $V_{CCO}$  is the supply voltage associated with the output.

[3]  $V_{CCI}+0.5\text{V}$  or  $V_{CCO}+0.5\text{V}$  should not exceed 6.5V.

[4]  $V_{CCO}$  is the supply voltage associated with the output.

### 3.2、Recommended operating conditions

Parameter	Symbol	Conditions	Min.	Max.	Unit	
supply voltage A	$V_{CC(A)}$	-	1.65	3.6	V	
supply voltage B	$V_{CC(B)}$	-	2.3	5.5	V	
input voltage	$V_I$	OE	0	5.5	V	
		Power-down or 3-state mode	A port	0	3.6	V
			B port	0	5.5	V
		Active mode	A, B port	0	$V_{CCI}$	V
output voltage	$V_O$	Power-down or 3-state mode	A port	0	3.6	V
			B port	0	5.5	V
		Active mode	A, B port	0	$V_{CCO}$	V
ambient temperature	$T_{amb}$	-	-40	+105	$^{\circ}\text{C}$	
input transition rise and fall rate	$\Delta t/\Delta V$	A or B port; push-pull driving	$V_{CC(A)}=1.65\text{V}$ to $3.6\text{V}$ ; $V_{CC(B)}=2.3\text{V}$ to $5.5\text{V}$	-	10	ns/V
		OE input	$V_{CC(A)}=1.65\text{V}$ to $3.6\text{V}$ ; $V_{CC(B)}=2.3\text{V}$ to $5.5\text{V}$	-	10	ns/V





Note:

- [1] The A and B sides of an unused I/O pair must be held in the same state, both at  $V_{CC1}$  or both at GND.
- [2]  $V_{CC(A)}$  must be less than or equal to  $V_{CC(B)}$ .
- [3]  $V_{CC1}$  is the supply voltage associated with the input.
- [4]  $V_{CC0}$  is the supply voltage associated with the output.

### 3.3、Electrical Characteristics

#### 3.3.1、DC Characteristics 1

(T<sub>amb</sub>=25°C, voltages are referenced to GND (ground=0V), unless otherwise specified)

Parameter	Symbol	Conditions	Min.	Typ.	Max.	Unit	
LOW-level output voltage	$V_{OL}$	A port; $V_I \leq 0.15V$ ; $V_{CC(B)}=1.65V$ to $5.5V$ ; $V_{CC(A)}=1.65V$ ; $I_O=-135\mu A$	-	0.25	-	V	
input leakage current	$I_I$	OE input; $V_I=0V$ to $3.6V$ ; $V_{CC(A)}=1.65V$ to $3.6V$ ; $V_{CC(B)}=2.3V$ to $5.5V$	-	-	$\pm 1$	$\mu A$	
OFF-state output current	$I_{OZ}$	A or B port; $V_O=0V$ or $V_{CC0}$ ; $V_{CC(A)}=1.65V$ to $3.6V$ ; $V_{CC(B)}=2.3V$ to $5.5V$	-	-	$\pm 1$	$\mu A$	
power-off leakage current	$I_{OFF}$	A port; $V_I$ or $V_O=0V$ to $3.6V$ ; $V_{CC(A)}=0V$ ; $V_{CC(B)}=0V$ to $5.5V$	-	-	$\pm 1$	$\mu A$	
		B port; $V_I$ or $V_O=0V$ to $5.5V$ ; $V_{CC(B)}=0V$ ; $V_{CC(A)}=0V$ to $3.6V$	-	-	$\pm 1$	$\mu A$	
input capacitance	$C_I$	OE input; $V_{CC(A)}=3.3V$ ; $V_{CC(B)}=3.3V$	-	2.6	-	pF	
input/output capacitance	$C_{I/O}$	A port; $V_{CC(A)}=3.3V$ ; $V_{CC(B)}=3.3V$	enabled	-	9	-	pF
			disabled	-	5.2	-	pF
		B port; $V_{CC(A)}=3.3V$ ; $V_{CC(B)}=3.3V$	enabled	-	10.5	-	pF
			disabled	-	9	-	pF
supply current	$I_{CC(A)}$	$V_{CC(A)}=1.8V$	$V_{CC(B)}=2.5V$	-	0.1	-	$\mu A$
			$V_{CC(B)}=3.3V$	-	0.1	-	$\mu A$
			$V_{CC(B)}=5.0V$	-	0.1	-	$\mu A$
		$V_{CC(A)}=2.5V$	$V_{CC(B)}=2.5V$	-	0.1	-	$\mu A$
			$V_{CC(B)}=3.3V$	-	0.1	-	$\mu A$
			$V_{CC(B)}=5.0V$	-	0.1	-	$\mu A$
		$V_{CC(A)}=3.3V$	$V_{CC(B)}=2.5V$	-	-	-	$\mu A$
			$V_{CC(B)}=3.3V$	-	0.1	-	$\mu A$
			$V_{CC(B)}=5.0V$	-	0.1	-	$\mu A$
	$I_{CC(B)}$	$V_{CC(A)}=1.8V$	$V_{CC(B)}=2.5V$	-	0.5	-	$\mu A$
			$V_{CC(B)}=3.3V$	-	1.5	-	$\mu A$
			$V_{CC(B)}=5.0V$	-	4.6	-	$\mu A$
		$V_{CC(A)}=2.5V$	$V_{CC(B)}=2.5V$	-	0.1	-	$\mu A$
			$V_{CC(B)}=3.3V$	-	0.8	-	$\mu A$
$V_{CC(B)}=5.0V$			-	3.8	-	$\mu A$	
$V_{CC(A)}=3.3V$	$V_{CC(B)}=2.5V$	-	-	-	$\mu A$		



			$V_{CC(B)}=3.3V$	-	0.1	-	uA
			$V_{CC(B)}=5.0V$	-	2.8	-	uA

Note:

[1]  $V_{CC(A)}$  must be less than or equal to  $V_{CC(B)}$ .

[2]  $V_{CCO}$  is the supply voltage associated with the output.

### 3.3.2、DC Characteristics 2

( $T_{amb}=-40^{\circ}C$  to  $+85^{\circ}C$ , voltages are referenced to GND (ground=0V), unless otherwise specified)

Parameter	Symbol	Conditions	Min.	Typ.	Max.	Unit	
HIGH-level input voltage	$V_{IH}$	A port	$V_{CC(A)}=1.65V$ to $1.95V$ ; $V_{CC(B)}=2.3V$ to $5.5V$	$V_{CC(A)}-0.2$	-	-	V
			$V_{CC(A)}=2.3V$ to $3.6V$ ; $V_{CC(B)}=2.3V$ to $5.5V$	$V_{CC(A)}-0.4$	-	-	V
		B port	$V_{CC(A)}=1.65V$ to $3.6V$ ; $V_{CC(B)}=2.3V$ to $5.5V$	$V_{CC(B)}-0.4$	-	-	V
		OE input	$V_{CC(A)}=1.65V$ to $3.6V$ ; $V_{CC(B)}=2.3V$ to $5.5V$	$0.65V_{CC(A)}$	-	-	V
LOW-level input voltage	$V_{IL}$	A or B port	$V_{CC(A)}=1.65V$ to $3.6V$ ; $V_{CC(B)}=2.3V$ to $5.5V$	-	-	0.15	V
		OE input	$V_{CC(A)}=1.65V$ to $3.6V$ ; $V_{CC(B)}=2.3V$ to $5.5V$	-	-	$0.35V_{CC(A)}$	V
HIGH-level output voltage	$V_{OH}$	A port; $I_O=-20uA$ ; $V_I \geq V_{CC(B)}-0.4V$	$V_{CC(A)}=1.65V$ to $3.6V$ ; $V_{CC(B)}=2.3V$ to $5.5V$	$0.67V_{CC(A)}$	-	-	V
		B port; $I_O=-20uA$ ; $V_I \geq V_{CC(A)}-0.2V$	$V_{CC(A)}=1.65V$ to $3.6V$ ; $V_{CC(B)}=2.3V$ to $5.5V$	$0.67V_{CC(B)}$	-	-	V
LOW-level output voltage	$V_{OL}$	A port; $V_I \leq 0.15V$ ; $V_{CC(B)}=1.65V$ to $5.5V$	$V_{CC(A)}=1.65V$ ; $I_O=-220uA$	-	-	0.4	V
			$V_{CC(A)}=2.3V$ ; $I_O=-300uA$	-	-	0.4	V
			$V_{CC(A)}=3.0V$ ; $I_O=-400uA$	-	-	0.55	V
		B port; $V_I \leq 0.15V$ ; $V_{CC(A)}=1.65V$ to $3.6V$	$V_{CC(B)}=1.65V$ ; $I_O=-220uA$	-	-	0.4	V
			$V_{CC(B)}=2.3V$ ; $I_O=-300uA$	-	-	0.4	V
			$V_{CC(B)}=3.0V$ ; $I_O=-400uA$	-	-	0.55	V
	$V_{CC(B)}=4.5V$ ; $I_O=-620uA$	-	-	0.55	V		
input leakage current	$I_I$	OE input; $V_I=0V$ to $3.6V$ ; $V_{CC(A)}=1.65V$ to $3.6V$ ; $V_{CC(B)}=2.3V$ to $5.5V$	-	-	$\pm 2$	uA	
OFF-state output current	$I_{OZ}$	A or B port; $V_O=0V$ or $V_{CCO}$ ; $V_{CC(A)}=1.65V$ to $3.6V$ ; $V_{CC(B)}=2.3V$ to $5.5V$	-	-	$\pm 2$	uA	
power-off leakage current	$I_{OFF}$	A port; $V_I$ or $V_O=0V$ to $3.6V$ ; $V_{CC(A)}=0V$ ; $V_{CC(B)}=0V$ to $5.5V$	-	-	$\pm 2$	uA	
		B port; $V_I$ or $V_O=0V$ to $3.6V$ ; $V_{CC(B)}=0V$ ; $V_{CC(A)}=0V$ to $5.5V$	-	-	$\pm 2$	uA	
supply current	$I_{CC}$	OE=0V or $V_{CC(A)}$ ; An, Bn open					
		$I_{CC(A)}$	$V_{CC(A)}=1.65V$ ; $V_{CC(B)}=1.65V$ to $5.5V$	-5	-	0.5	uA



			$V_{CC(A)}=1.65V$ to $3.6V$ ; $V_{CC(B)}=2.3V$ to $5.5V$	-2	-	1.2	$\mu A$		
			$V_{CC(A)}=3.6V$ ; $V_{CC(B)}=0V$	-	-	1.0	$\mu A$		
			$V_{CC(A)}=0V$ ; $V_{CC(B)}=5.5V$	-1	-	-	$\mu A$		
		$I_{CC(B)}$			$V_{CC(A)}=1.65V$ ; $V_{CC(B)}=1.65V$ to $5.5V$	-	-	22	$\mu A$
					$V_{CC(A)}=1.65V$ to $3.6V$ ; $V_{CC(B)}=2.3V$ to $5.5V$	-	-	20	$\mu A$
					$V_{CC(A)}=3.6V$ ; $V_{CC(B)}=0V$	-1	-	-	$\mu A$
					$V_{CC(A)}=0V$ ; $V_{CC(B)}=5.5V$	-	-	2	$\mu A$
		$I_{CC(A)}+I_{CC(B)}$			$V_{CC(A)}=1.65V$ ; $V_{CC(B)}=1.65V$ to $5.5V$	-	-	17	$\mu A$
					$V_{CC(A)}=1.65V$ to $3.6V$ ; $V_{CC(B)}=2.3V$ to $5.5V$	-	-	20	$\mu A$

Note:

[1]  $V_{CC(A)}$  must be less than or equal to  $V_{CC(B)}$ .

[2]  $V_{CCO}$  is the supply voltage associated with the output.

### 3.3.3、DC Characteristics 3

( $T_{amb}=-40^{\circ}C$  to  $+105^{\circ}C$ , voltages are referenced to GND (ground=0V), unless otherwise specified)

Parameter	Symbol	Conditions		Min.	Typ.	Max.	Unit
HIGH-level input voltage	$V_{IH}$	A port	$V_{CC(A)}=1.65V$ to $1.95V$ ; $V_{CC(B)}=2.3V$ to $5.5V$	$V_{CC(A)}-0.2$	-	-	V
			$V_{CC(A)}=2.3V$ to $3.6V$ ; $V_{CC(B)}=2.3V$ to $5.5V$	$V_{CC(A)}-0.4$	-	-	V
		B port	$V_{CC(A)}=1.65V$ to $3.6V$ ; $V_{CC(B)}=2.3V$ to $5.5V$	$V_{CC(B)}-0.4$	-	-	V
		OE input	$V_{CC(A)}=1.65V$ to $3.6V$ ; $V_{CC(B)}=2.3V$ to $5.5V$	$0.65V_{CC(A)}$	-	-	V
LOW-level input voltage	$V_{IL}$	A or B port	$V_{CC(A)}=1.65V$ to $3.6V$ ; $V_{CC(B)}=2.3V$ to $5.5V$	-	-	0.15	V
		OE input	$V_{CC(A)}=1.65V$ to $3.6V$ ; $V_{CC(B)}=2.3V$ to $5.5V$	-	-	$0.35V_{CC(A)}$	V
HIGH-level output voltage	$V_{OH}$	A port; $I_O=-20\mu A$ ; $V_I \geq V_{CC(B)}-0.4V$	$V_{CC(A)}=1.65V$ to $3.6V$ ; $V_{CC(B)}=2.3V$ to $5.5V$	$0.67V_{CC(A)}$	-	-	V
		B port; $I_O=-20\mu A$ ; $V_I \geq V_{CC(A)}-0.2V$	$V_{CC(A)}=1.65V$ to $3.6V$ ; $V_{CC(B)}=2.3V$ to $5.5V$	$0.67V_{CC(B)}$	-	-	V
LOW-level output voltage	$V_{OL}$	A port; $V_I \leq 0.15V$ ; $V_{CC(B)}=1.65V$ to $5.5V$	$V_{CC(A)}=1.65V$ ; $I_O=-220\mu A$	-	-	0.4	V
			$V_{CC(A)}=2.3V$ ; $I_O=-300\mu A$	-	-	0.4	V
			$V_{CC(A)}=3.0V$ ; $I_O=-400\mu A$	-	-	0.55	V
		B port; $V_I \leq 0.15V$ ; $V_{CC(A)}=1.65V$ to $3.6V$	$V_{CC(B)}=1.65V$ ; $I_O=-220\mu A$	-	-	0.4	V
			$V_{CC(B)}=2.3V$ ; $I_O=-300\mu A$	-	-	0.4	V
			$V_{CC(B)}=3.0V$ ; $I_O=-400\mu A$	-	-	0.55	V
			$V_{CC(B)}=4.5V$ ; $I_O=-620\mu A$	-	-	0.55	V



input leakage current	$I_I$	OE input; $V_I=0V$ to $3.6V$ ; $V_{CC(A)}=1.65V$ to $1.95V$ ; $V_{CC(B)}=2.3V$ to $5.5V$	-	-	$\pm 12$	$\mu A$	
OFF-state output current	$I_{OZ}$	A or B port; $V_O=0V$ or $V_{CCO}$ ; $V_{CC(A)}=1.65V$ to $1.95V$ ; $V_{CC(B)}=2.3V$ to $5.5V$	-	-	$\pm 12$	$\mu A$	
power-off leakage current	$I_{OFF}$	A port; $V_I$ or $V_O=0V$ to $3.6V$ ; $V_{CC(A)}=0V$ ; $V_{CC(B)}=0V$ to $5.5V$	-	-	$\pm 12$	$\mu A$	
		B port; $V_I$ or $V_O=0V$ to $3.6V$ ; $V_{CC(B)}=0V$ ; $V_{CC(A)}=0V$ to $5.5V$	-	-	$\pm 12$	$\mu A$	
supply current	$I_{CC}$	OE=0V or $V_{CC(A)}$ ; An, Bn open					
		$I_{CC(A)}$	$V_{CC(A)}=1.65V$ ; $V_{CC(B)}=1.65V$ to $5.5V$	-5	-	1	$\mu A$
			$V_{CC(A)}=1.65V$ to $3.6V$ ; $V_{CC(B)}=2.3V$ to $5.5V$	-2	-	2	$\mu A$
			$V_{CC(A)}=3.6V$ ; $V_{CC(B)}=0V$	-	-	2	$\mu A$
			$V_{CC(A)}=0V$ ; $V_{CC(B)}=5.5V$	-1	-	-	$\mu A$
		$I_{CC(B)}$	$V_{CC(A)}=1.65V$ ; $V_{CC(B)}=1.65V$ to $5.5V$	-	-	60	$\mu A$
			$V_{CC(A)}=1.65V$ to $3.6V$ ; $V_{CC(B)}=2.3V$ to $5.5V$	-	-	20	$\mu A$
			$V_{CC(A)}=3.6V$ ; $V_{CC(B)}=0V$	-1	-	-	$\mu A$
			$V_{CC(A)}=0V$ ; $V_{CC(B)}=5.5V$	-	-	12	$\mu A$
		$I_{CC(A)}+I_{CC(B)}$	$V_{CC(A)}=1.65V$ ; $V_{CC(B)}=1.65V$ to $5.5V$	-	-	65	$\mu A$
$V_{CC(A)}=1.65V$ to $3.6V$ ; $V_{CC(B)}=2.3V$ to $5.5V$	-		-	20	$\mu A$		

Note:

- [1]  $V_{CC(A)}$  must be less than or equal to  $V_{CC(B)}$ .  
 [2]  $V_{CCO}$  is the supply voltage associated with the output.



### 3.3.4、AC Characteristics 1

( $T_{amb}=25^{\circ}\text{C}$ , voltages are referenced to GND (ground=0V), unless otherwise specified)

Parameter	Symbol	Conditions	$V_{CC(B)}$				Unit
			1.8V± 0.15V	2.5V± 0.2V	3.3V± 0.3V	5.0V± 0.5V	
HIGH to LOW propagation delay	$t_{PHL}$	A to B	6.5	5.9	5.7	5.5	ns
LOW to HIGH propagation delay	$t_{PLH}$	A to B	7.1	6.3	6.2	6.6	ns
HIGH to LOW propagation delay	$t_{PHL}$	B to A	6.2	5.4	5.1	5	ns
LOW to HIGH propagation delay	$t_{PLH}$	B to A	5.6	4.1	3.6	3.2	ns
enable time	$t_{en}$	OE to A; B <sup>[1]</sup>	200	200	200	200	ns
disable time	$t_{dis}$	OE to A; no external load <sup>[1][2]</sup>	12	12	12	12	ns
		OE to B; no external load <sup>[2]</sup>	12	12	12	12	ns
		OE to A; see Figure 3	90	90	90	90	ns
		OE to B; see Figure 3	95	75	100	75	ns
LOW to HIGH output transition time	$t_{TLH}$	A port	6.5	5.2	4.8	4.4	ns
		B port	6.6	4.3	2.1	1.5	ns
HIGH to LOW output transition time	$t_{THL}$	A port	5.8	4.8	4.3	3.8	ns
		B port	3.6	2.2	1.8	1.5	ns
output skew time	$t_{sk(o)}$	between channels <sup>[3]</sup>	1	1	1	1	ns
pulse width	$t_w$	data inputs	20	16.7	16.7	16.7	ns
data rate	$f_{data}$	-	50	60	60	60	Mbps

Note:

[1]  $t_{en}$  is the same as  $t_{PZL}$  and  $t_{PZH}$ ;  $t_{dis}$  is the same as  $t_{PLZ}$  and  $t_{PHZ}$ .

[2] These values are guaranteed by design.

[3] Skew between any two outputs of the same package switching in the same direction.



### 3.3.5、AC Characteristics 2

( $T_{amb} = -40^{\circ}\text{C}$  to  $+85^{\circ}\text{C}$ , voltages are referenced to GND (ground=0V), unless otherwise specified)

Parameter	Symbol	Conditions	$V_{CC(B)}$								Unit
			1.8V±0.15V		2.5V±0.2V		3.3V±0.3V		5.0V±0.5V		
			Min.	Max.	Min.	Max.	Min.	Max.	Min.	Max.	
<b><math>V_{CC(A)} = 1.8V \pm 0.15V</math></b>											
HIGH to LOW propagation delay	$t_{PHL}$	A to B	-	9.7	-	7.3	-	6.5	-	5.9	ns
LOW to HIGH propagation delay	$t_{PLH}$	A to B	-	11.3	-	8.4	-	7.4	-	6.5	ns
HIGH to LOW propagation delay	$t_{PHL}$	B to A	-	9.8	-	8.0	-	7.4	-	7.0	ns
LOW to HIGH propagation delay	$t_{PLH}$	B to A	-	10.2	-	7.0	-	5.8	-	5.0	ns
enable time	$t_{en}$	OE to A; B <sup>[1]</sup>	-	200	-	200	-	200	-	200	ns
disable time	$t_{dis}$	OE to A; no external load <sup>[1][2]</sup>	-	13	-	13	-	13	-	13	ns
		OE to B; no external load <sup>[2]</sup>	-	16	-	13	-	13	-	13	ns
		OE to A; see Figure 3	-	140	-	140	-	140	-	145	ns
		OE to B; see Figure 3	-	165	-	125	-	175	-	125	ns
LOW to HIGH output transition time	$t_{TLH}$	A port	2.2	11.9	2.0	8.6	1.9	7.8	1.9	7.2	ns
		B port	2.8	12.2	1.8	7.7	1.2	5.3	0.7	2.9	ns
HIGH to LOW output transition time	$t_{THL}$	A port	1.8	8.8	1.3	6.6	0.9	5.7	0.6	4.9	ns
		B port	1.3	8.3	1.0	5.4	0.9	3.9	0.7	3.0	ns
output skew	$t_{sk(o)}$	between channels <sup>[3]</sup>	-	1	-	1	-	1	-	1	ns
pulse width	$t_w$	data inputs	22.2	-	16.7	-	16.7	-	16.7	-	ns
data rate	$f_{data}$	-	-	45	-	60	-	60	-	60	Mbps
<b><math>V_{CC(A)} = 2.5V \pm 0.2V</math></b>											
HIGH to LOW propagation delay	$t_{PHL}$	A to B	-	-	-	6.2	-	5.3	-	4.7	ns
LOW to HIGH propagation delay	$t_{PLH}$	A to B	-	-	-	6.8	-	5.9	-	5.2	ns
HIGH to LOW propagation delay	$t_{PHL}$	B to A	-	-	-	5.9	-	4.8	-	4.2	ns



LOW to HIGH propagation delay	$t_{PLH}$	B to A	-	-	-	6.2	-	4.6	-	3.6	ns
enable time	$t_{en}$	OE to A; B <sup>[1]</sup>	-	-	-	200	-	200	-	200	ns
disable time	$t_{dis}$	OE to A; no external load <sup>[1][2]</sup>	-	-	-	9	-	9	-	9	ns
		OE to B; no external load <sup>[2]</sup>	-	-	-	11	-	9	-	9	ns
		OE to A	-	-	-	105	-	105	-	105	ns
		OE to B	-	-	-	125	-	175	-	120	ns
LOW to HIGH output transition time	$t_{TLH}$	A port	-	-	1.7	7.3	1.7	6.4	1.8	5.8	ns
		B port	-	-	1.8	7.3	1.3	5.4	0.8	3.3	ns
HIGH to LOW output transition time	$t_{THL}$	A port	-	-	1.3	5.7	0.8	4.7	0.6	3.8	ns
		B port	-	-	1.1	5.4	0.9	4.1	0.7	3.0	ns
output skew time	$t_{sk(o)}$	between channels <sup>[3]</sup>	-	-	-	1	-	1.2	-	1	ns
pulse width	$t_W$	data inputs	-	-	14	-	11	-	11	-	ns
data rate	$f_{data}$	-	-	-	-	70	-	90	-	90	Mbps
<b><math>V_{CC(A)}=3.3V\pm 0.3V</math></b>											
HIGH to LOW propagation delay	$t_{PHL}$	A to B	-	-	-	-	-	4.9	-	4.2	ns
LOW to HIGH propagation delay	$t_{PLH}$	A to B	-	-	-	-	-	5.2	-	4.6	ns
HIGH to LOW propagation delay	$t_{PHL}$	B to A	-	-	-	-	-	4.7	-	3.8	ns
LOW to HIGH propagation delay	$t_{PLH}$	B to A	-	-	-	-	-	4.7	-	4.3	ns
enable time	$t_{en}$	OE to A; B <sup>[1]</sup>	-	-	-	-	-	200	-	200	ns
disable time	$t_{dis}$	OE to A; no external load <sup>[1][2]</sup>	-	-	-	-	-	8	-	8	ns
		OE to B; no external load <sup>[2]</sup>	-	-	-	-	-	8	-	8	ns
		OE to A	-	-	-	-	-	150	-	150	ns
		OE to B	-	-	-	-	-	170	-	120	ns
LOW to HIGH output transition time	$t_{TLH}$	A port	-	-	-	-	1.6	5.7	1.8	5.0	ns
		B port	-	-	-	-	1.5	5.4	0.9	3.9	ns
HIGH to LOW output transition time	$t_{THL}$	A port	-	-	-	-	1.0	4.5	0.6	3.5	ns
		B port	-	-	-	-	1.0	4.2	0.8	3.1	ns



output skew time	$t_{sk(o)}$	between channels <sup>[3]</sup>	-	-	-	-	-	1	-	1	ns
pulse width	$t_W$	data inputs	-	-	-	-	11	-	9	-	ns
data rate	$f_{data}$	-	-	-	-	-	-	90	-	110	Mbps

Note:

[1]  $t_{en}$  is the same as  $t_{PZL}$  and  $t_{PZH}$ ;  $t_{dis}$  is the same as  $t_{PLZ}$  and  $t_{PHZ}$ .

[2] These values are guaranteed by design.

[3] Skew between any two outputs of the same package switching in the same direction.

### 3.3.6. AC Characteristics 3

( $T_{amb} = -40^\circ\text{C}$  to  $+105^\circ\text{C}$ , voltages are referenced to GND (ground=0V), unless otherwise specified)

Parameter	Symbol	Conditions	$V_{CC(B)}$								Unit
			1.8V±0.15V		2.5V±0.2V		3.3V±0.3V		5.0V±0.5V		
			Min.	Max.	Min.	Max.	Min.	Max.	Min.	Max.	
$V_{CC(A)} = 1.8V \pm 0.15V$											
HIGH to LOW propagation delay	$t_{PHL}$	A to B	-	12.1	-	9.1	-	8.1	-	7.4	ns
LOW to HIGH propagation delay	$t_{PLH}$	A to B	-	14.1	-	10.5	-	9.3	-	8.1	ns
HIGH to LOW propagation delay	$t_{PHL}$	B to A	-	12.3	-	10.0	-	9.3	-	8.8	ns
LOW to HIGH propagation delay	$t_{PLH}$	B to A	-	12.8	-	8.8	-	7.3	-	6.3	ns
enable time	$t_{en}$	OE to A; B <sup>[1]</sup>	-	200	-	200	-	200	-	200	ns
disable time	$t_{dis}$	OE to A; no external load <sup>[1][2]</sup>	-	14	-	14	-	14	-	14	ns
		OE to B; no external load <sup>[2]</sup>	-	17	-	14	-	14	-	14	ns
		OE to A; see Figure 3	-	140	-	140	-	140	-	145	ns
		OE to B; see Figure 3	-	165	-	125	-	175	-	125	ns
LOW to HIGH output transition time	$t_{TLH}$	A port	2.2	14.9	2.0	10.8	1.9	9.8	1.9	9.0	ns
		B port	2.8	15.3	1.8	9.6	1.2	6.6	0.7	3.6	ns
HIGH to LOW output transition time	$t_{THL}$	A port	1.8	11.0	1.3	8.3	0.9	7.1	0.6	6.1	ns
		B port	1.3	10.4	1.0	6.8	0.9	4.9	0.7	3.8	ns
output skew	$t_{sk(o)}$	between channels <sup>[3]</sup>	-	1.1	-	1.1	-	1.1	-	1.1	ns
pulse width	$t_W$	data inputs	25	-	20	-	20	-	20	-	ns
data rate	$f_{data}$	-	-	40	-	50	-	50	-	50	Mbps
$V_{CC(A)} = 2.5V \pm 0.2V$											





HIGH to LOW propagation delay	$t_{PHL}$	A to B	-	-	-	7.8	-	6.6	-	5.9	ns
LOW to HIGH propagation delay	$t_{PLH}$	A to B	-	-	-	8.5	-	7.4	-	6.5	ns
HIGH to LOW propagation delay	$t_{PHL}$	B to A	-	-	-	7.4	-	6.0	-	5.3	ns
LOW to HIGH propagation delay	$t_{PLH}$	B to A	-	-	-	7.8	-	5.8	-	4.5	ns
enable time	$t_{en}$	OE to A; B <sup>[1]</sup>	-	-	-	200	-	200	-	200	ns
disable time	$t_{dis}$	OE to A; no external load <sup>[1][2]</sup>	-	-	-	10	-	10	-	10	ns
		OE to B; no external load <sup>[2]</sup>	-	-	-	12	-	10	-	10	ns
		OE to A	-	-	-	105	-	105	-	105	ns
		OE to B	-	-	-	125	-	175	-	120	ns
LOW to HIGH output transition time	$t_{TLH}$	A port	-	-	1.7	9.1	1.7	8.0	1.8	7.3	ns
		B port	-	-	1.8	9.1	1.3	6.8	0.9	4.1	ns
HIGH to LOW output transition time	$t_{THL}$	A port	-	-	1.3	7.1	0.8	5.9	0.6	4.8	ns
		B port	-	-	1.1	6.8	0.9	5.1	0.7	3.8	ns
output skew time	$t_{sk(o)}$	between channels <sup>[3]</sup>	-	-	-	1.1	-	1.3	-	1.1	ns
pulse width	$t_w$	data inputs	-	-	16.7	-	12.5	-	12.5	-	ns
data rate	$f_{data}$	-	-	-	-	60	-	80	-	80	Mbps
<b><math>V_{CC(A)}=3.3V\pm 0.3V</math></b>											
HIGH to LOW propagation delay	$t_{PHL}$	A to B	-	-	-	-	-	6.1	-	5.3	ns
LOW to HIGH propagation delay	$t_{PLH}$	A to B	-	-	-	-	-	6.5	-	5.8	ns
HIGH to LOW propagation delay	$t_{PHL}$	B to A	-	-	-	-	-	5.9	-	4.8	ns
LOW to HIGH propagation delay	$t_{PLH}$	B to A	-	-	-	-	-	5.9	-	5.4	ns
enable time	$t_{en}$	OE to A; B <sup>[1]</sup>	-	-	-	-	-	200	-	200	ns
disable time	$t_{dis}$	OE to A; no external load <sup>[1][2]</sup>	-	-	-	-	-	9	-	9	ns
		OE to B; no external load <sup>[2]</sup>	-	-	-	-	-	9	-	9	ns



		OE to A	-	-	-	-	-	150	-	150	ns
		OE to B	-	-	-	-	-	170	-	120	ns
LOW to HIGH output transition time	$t_{TLH}$	A port	-	-	-	-	1.6	7.1	1.8	6.3	ns
		B port	-	-	-	-	1.5	6.8	0.9	4.9	ns
HIGH to LOW output transition time	$t_{THL}$	A port	-	-	-	-	1.0	5.6	0.7	4.4	ns
		B port	-	-	-	-	1.0	5.3	0.8	3.9	ns
output skew time	$t_{sk(o)}$	between channels <sup>[3]</sup>	-	-	-	-	-	1.1	-	1.1	ns
pulse width	$t_W$	data inputs	-	-	-	-	13	-	10	-	ns
data rate	$f_{data}$	-	-	-	-	-	-	80	-	100	Mbps

Note:

[1]  $t_{en}$  is the same as  $t_{PZL}$  and  $t_{PZH}$ ;  $t_{dis}$  is the same as  $t_{PLZ}$  and  $t_{PHZ}$ .

[2] These values are guaranteed by design.

[3] Skew between any two outputs of the same package switching in the same direction.

## 4、Testing Circuit

### 4.1、AC Testing Circuit

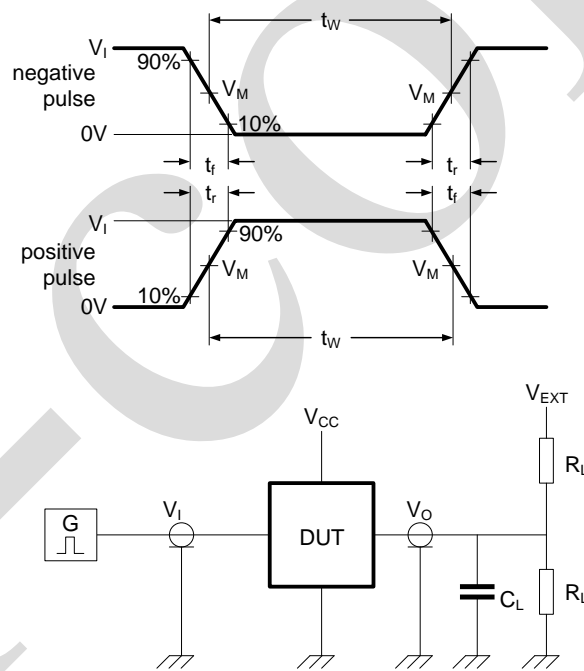

Figure 1. Test circuit for measuring switching times

All input pulses are supplied by generators having the following characteristics:  $PRR \leq 10\text{MHz}$ ;  $Z_0 = 50\Omega$ ;  $dV/dt \geq 1.0\text{V/ns}$ .

$R_L$ =Load resistance.

$C_L$ =Load capacitance including jig and probe capacitance.

$V_{EXT}$ =External voltage for measuring switching times.



## 4.2、AC Testing Waveforms

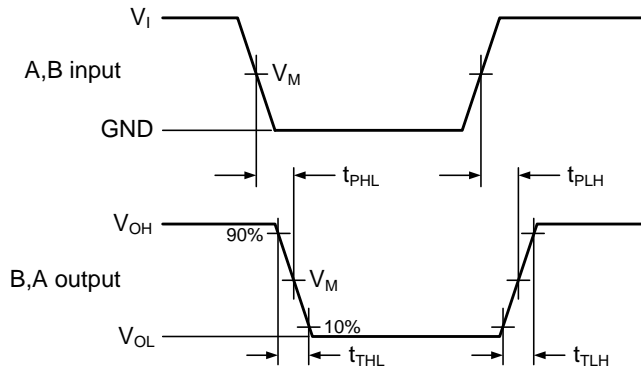

Figure 2. The data input (A, B) to data output (B, A) propagation delay times

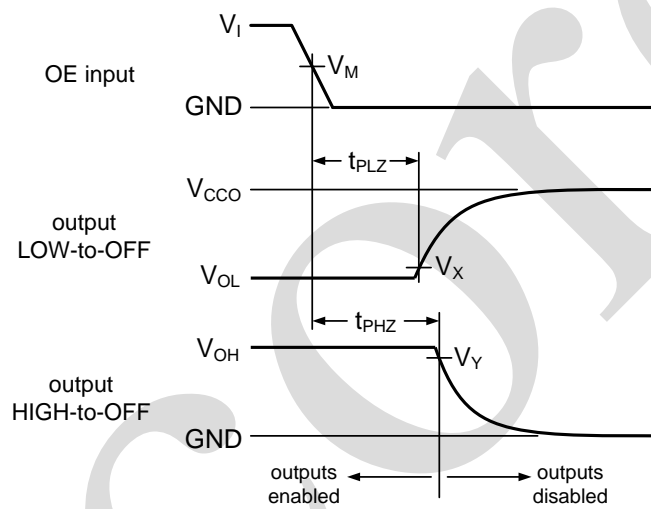
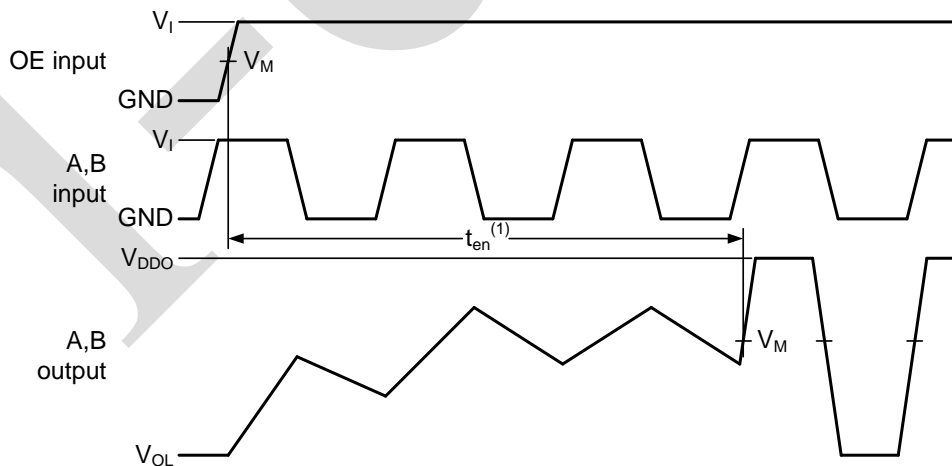

Figure 3. Disable times



(1) The enable time ( $t_{en}$ ) indicates the amount of time the user must allow for one one-shot circuitry to become operational after OE is taken HIGH. See also Section 5.6.

Figure 4. Enable times



### 4.3、 Measurement Points

Supply voltage	Input	Output		
$V_{CCO}$	$V_M$	$V_M$	$V_X$	$V_Y$
1.8V±0.15V	0.5V <sub>CCI</sub>	0.5V <sub>CCO</sub>	$V_{OL}+0.15V$	$V_{OH}-0.15V$
2.5V±0.2V	0.5V <sub>CCI</sub>	0.5V <sub>CCO</sub>	$V_{OL}+0.15V$	$V_{OH}-0.15V$
3.3V±0.3V	0.5V <sub>CCI</sub>	0.5V <sub>CCO</sub>	$V_{OL}+0.3V$	$V_{OH}-0.3V$
5.0V±0.5V	0.5V <sub>CCI</sub>	0.5V <sub>CCO</sub>	$V_{OL}+0.3V$	$V_{OH}-0.3V$

Note:

[1]  $V_{CCI}$  is the supply voltage associated with the input.

[2]  $V_{CCO}$  is the supply voltage associated with the output.

### 4.4、 Test Data

Supply voltage		Input		Load		$V_{EXT}$		
$V_{CC(A)}$	$V_{CC(B)}$	$V_I$	$\Delta t/\Delta V$	$C_L$	$R_L$	$t_{PLH}, t_{PHL}$	$t_{PZH}, t_{PHZ}$	$t_{PZL}, t_{PLZ}$
1.65V to 3.6V	2.3V to 5.5V	$V_{CCI}$	$\leq 1.0ns/V$	15pF	50k $\Omega$ , 1M $\Omega$	open	open	2V <sub>CCO</sub>

Note:

[1]  $V_{CCI}$  is the supply voltage associated with the input.

[2] For measuring data rate, pulse width, propagation delay and output rise and fall measurements,  $R_L=1M\Omega$ . For measuring enable and disable times,  $R_L=50K\Omega$ .

[3]  $V_{CCO}$  is the supply voltage associated with the output.

## 5、 Typical Application Circuit And Application Note

### 5.1、 Voltage Level-translation Applications

The AiPTS010X can be used in point-to-point applications to interface between devices or systems operating at different supply voltages. The device is primarily targeted at I<sup>2</sup>C or 1-wire which use open-drain drivers, it may also be used in applications where push-pull drivers are connected to the ports, however the AiPTB010X may be more suitable.

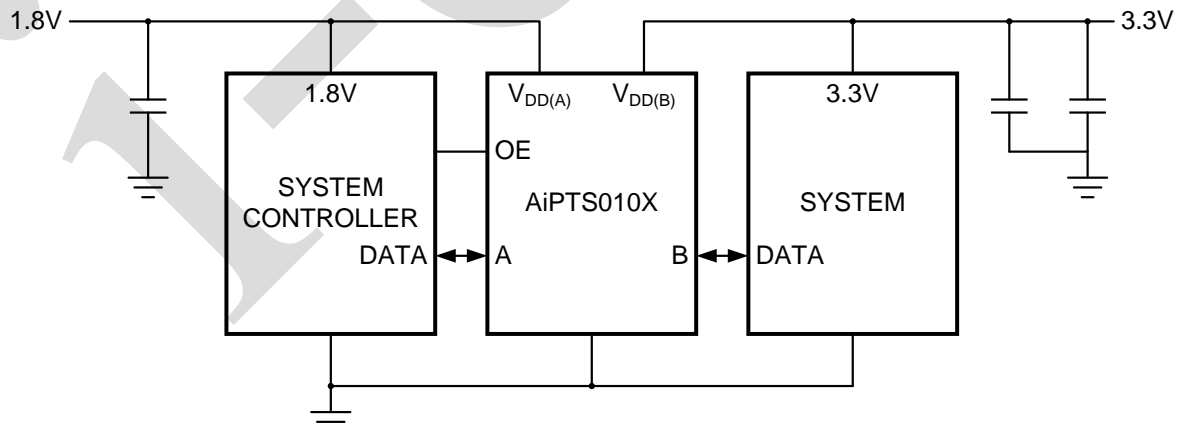

Figure 5. Typical operating circuit



## 5.2、 Architecture

The architecture of the AiPTS010X is shown in Figure 6. The device does not require an extra input signal to control the direction of data flow from A to B or B to A.

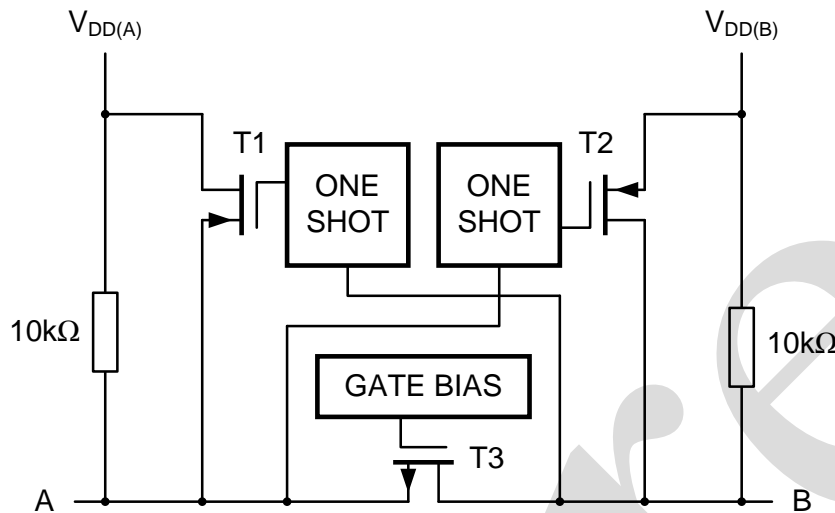

Figure 6. Architecture of AiPTS010X I/O cell (one channel)

The AiPTS010X is a "switch" type voltage translator, it employs two key circuits to enable voltage translation:

1. A pass-gate transistor (N-channel) that ties the ports together.
2. An output edge-rate accelerator that detects and accelerates rising edges on the I/O pins.

The gate bias voltage of the pass gate transistor (T3) is set at approximately one threshold voltage above the  $V_{CC}$  level of the low-voltage side. During a LOW-to-HIGH transition the output one-shot accelerates the output transition by switching on the PMOS transistors (T1, T2) bypassing the 10K $\Omega$  pull-up resistors and increasing current drive capability. The one-shot is activated once the input transition reaches approximately  $V_{CC}/2$ ; it is de-activated approximately 50ns after the output reaches  $V_{CC}/2$ . During the acceleration time the driver output resistance is between approximately 50 $\Omega$  and 70 $\Omega$ . To avoid signal contention and minimize dynamic  $I_{DD}$ , the user should wait for the one-shot circuit to turn-off before applying a signal in the opposite direction. Pull-up resistors are included in the device for DC current sourcing capability.

## 5.3、 Input Driver Requirements

As the AiPTS010X is a switch type translator, properties of the input driver directly effect the output signal. The external open-drain or push-pull driver applied to an I/O determines the static current sinking capability of the system; the max data rate, HIGH-to-LOW output transition time ( $t_{THL}$ ) and propagation delay ( $t_{PHL}$ ) are dependent upon the output impedance and edge-rate of the external driver. The limits provided for these parameters in the datasheet assume a driver with output impedance below 50 $\Omega$  is used.



## 5.4、 Output Load Considerations

The maximum lumped capacitive load that can be driven is dependant upon the one-shot pulse duration. In cases with very heavy capacitive loading there is a risk that the output will not reach the positive rail within the one-shot pulse duration. To avoid excessive capacitive loading and to ensure correct triggering of the one-shot it's recommended to use short trace lengths and low capacitance connectors on AiPTS010X PCB layouts. To ensure low impedance termination and avoid output signal oscillations and one-shot re-triggering, the length of the PCB trace should be such that the round trip delay of any reflection is within the one-shot pulse duration (approximately 50ns).

## 5.5、 Power Up

During operation  $V_{CC(A)}$  must never be higher than  $V_{CC(B)}$ , however during power-up  $V_{CC(A)} \geq V_{CC(B)}$  does not damage the device, so either power supply can be ramped up first. There is no special power-up sequencing required. The AiPTS010X includes circuitry that disables all output ports when either  $V_{CC(A)}$  or  $V_{CC(B)}$  is switched off.

## 5.6、 Enable And Disable

An output enable input (OE) is used to disable the device. Setting OE=LOW causes all I/Os to assume the high-impedance OFF-state. The disable time ( $t_{dis}$  with no external load) indicates the delay between when OE goes LOW and when outputs actually become disabled. The enable time ( $t_{en}$ ) indicates the amount of time the user must allow for one one-shot circuitry to become operational after OE is taken HIGH. To ensure the high-impedance OFF-state during power-up or power-down, pin OE should be tied to GND through a pull-down resistor, the minimum value of the resistor is determined by the current-sourcing capability of the driver.

## 5.7、 Pull-up Or Pull-down Resistors On I/O Lines

The AiPTS010X has the pull-up resistors dynamically change value based on whether a low or a high is being passed through the I/O line. Each A-port I/O has a pull-up resistor ( $R_{PUA}$ ) to  $V_{CCA}$  and each B-port I/O has a pull-up resistor ( $R_{PUB}$ ) to  $V_{CCB}$ .  $R_{PUA}$  and  $R_{PUB}$  have a value of 40k $\Omega$  when the output is driving LOW.  $R_{PUA}$  and  $R_{PUB}$  have a value of 4k $\Omega$  when the output is driving HIGH.  $R_{PUA}$  and  $R_{PUB}$  are disabled when OE=LOW. This feature provides lower static power consumption (when the I/Os are passing a LOW) and supports lower  $V_{OL}$  values for the same size pass-gate transistor and helps improve simultaneous switching performance.



6、Package Information

6.1、SOT23-6

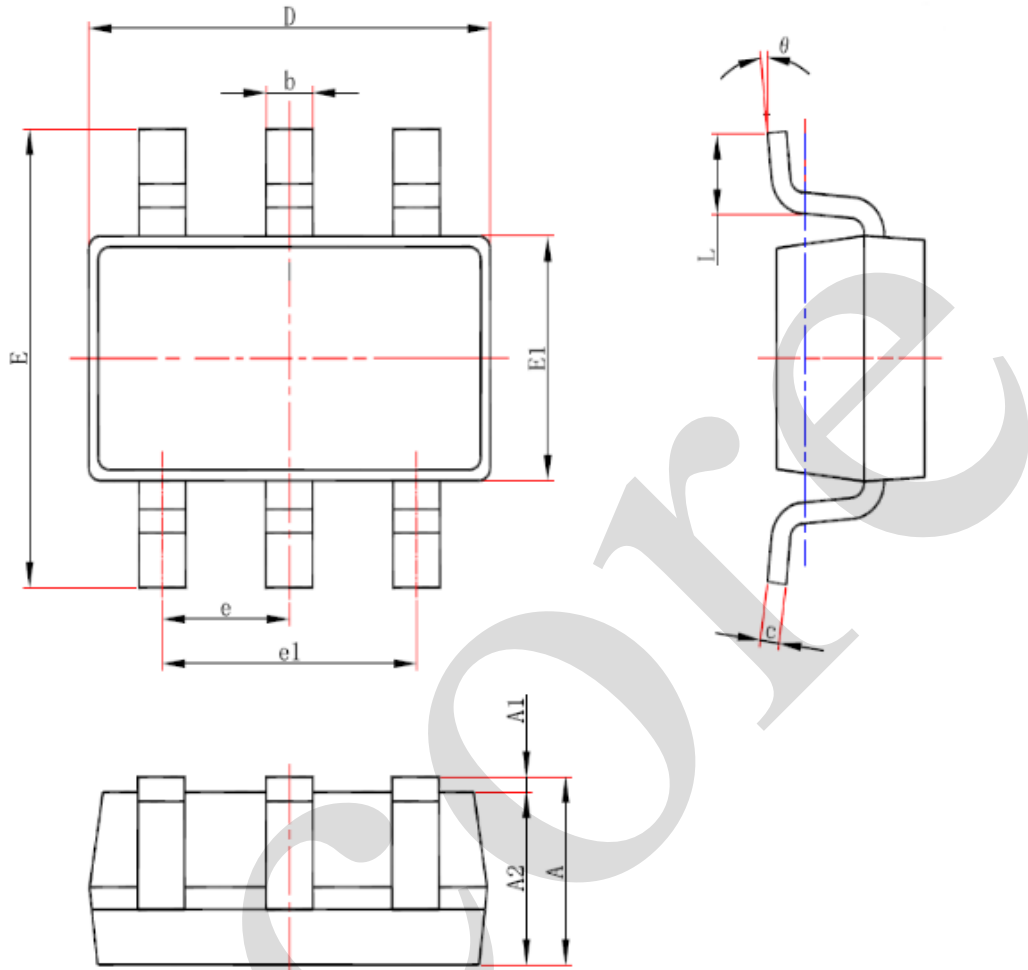

Symbol	Dimensions (mm)	
	Min.	Max.
A	-	1.25
A1	0.00	0.12
A2	1.00	1.20
b	0.30	0.50
c	0.10	0.20
D	2.82	3.02
E	2.60	3.00
E1	1.50	1.70
e	0.95	
e1	1.80	2.00
L	0.30	0.60
θ	0°	8°



## 6.2、SOT-363

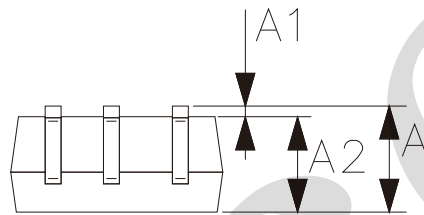
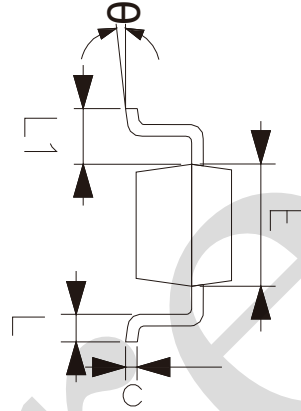
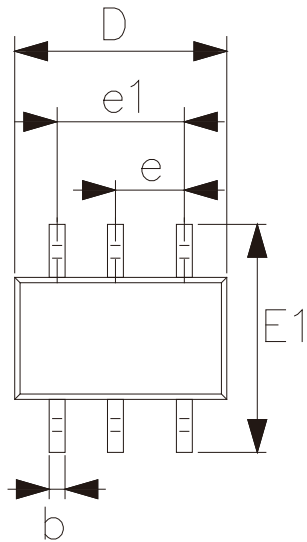

Symbol	Dimensions (mm)	
	Min.	Max.
A	0.90	1.10
A1	0.00	0.10
A2	0.90	1.00
b	0.15	0.35
c	0.11	0.175
D	2.00	2.20
E1	2.15	2.45
E	1.15	1.35
e	0.65	
e1	1.20	1.40
L	0.26	0.46
L1	0.525	
$\theta$	0°	8°





## 6.3、TSSOP8

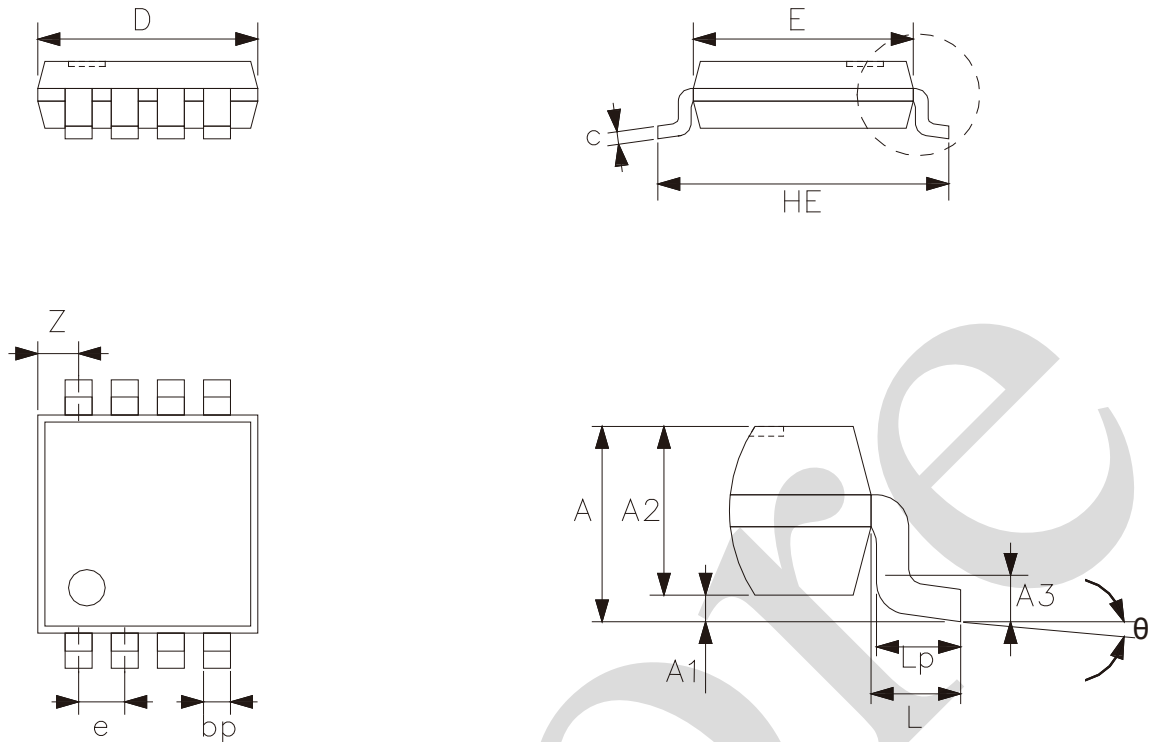

Symbol	Dimensions (mm)	
	Min.	Max.
A	-	1.10
A1	0	0.15
A2	0.75	0.95
A3	0.25	
bp	0.22	0.38
c	0.08	0.18
D	2.90	3.10
E	2.90	3.10
HE	3.90	4.10
L	0.50	
Lp	0.33	0.47
e	0.65	
Z	0.35	0.70
$\theta$	0°	8°



6.4. VSSOP8

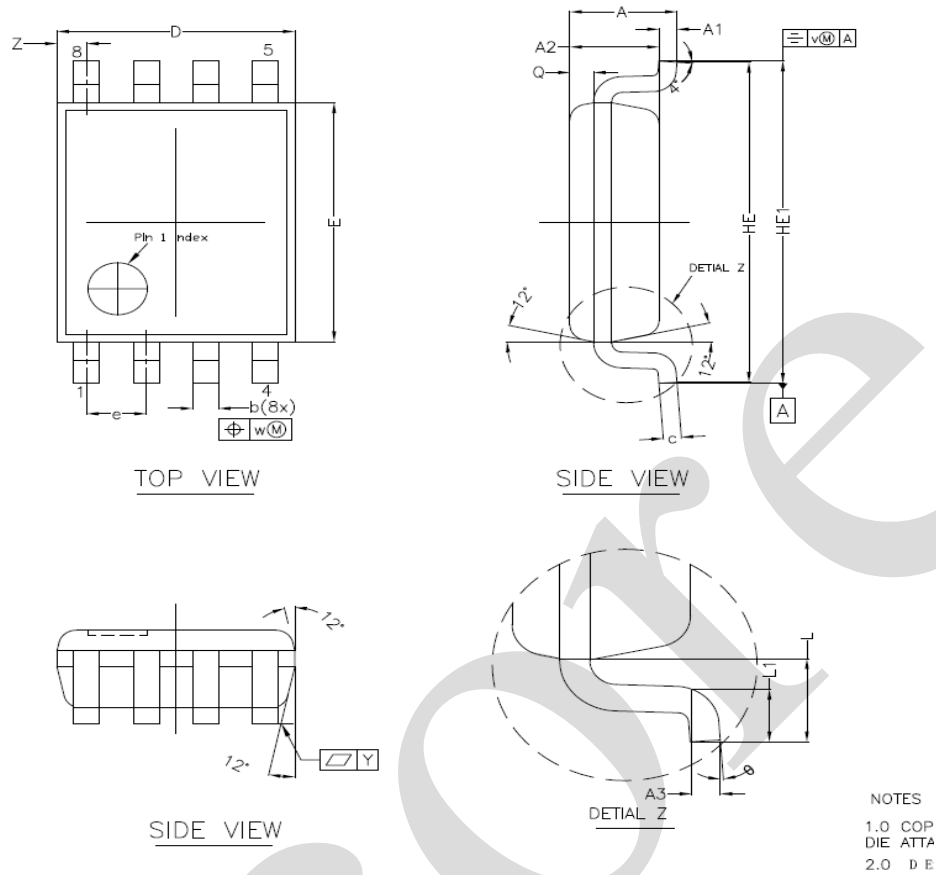

Symbol	Dimensions (mm)	
	Min.	Max.
A	-	1.00
A1	0.00	0.15
A2	0.60	0.85
A3	0.12	
Q	0.19	0.21
b	0.17	0.27
c	0.08	0.23
D	1.90	2.10
E	2.20	2.40
HE	3.00	3.20
HE1	3.00	3.40
e	0.50	
L	0.40	
L1	0.15	0.40
Y	0.10	
Z	0.10	0.40
$\theta$	0°	8°



## 6.5、XSON8

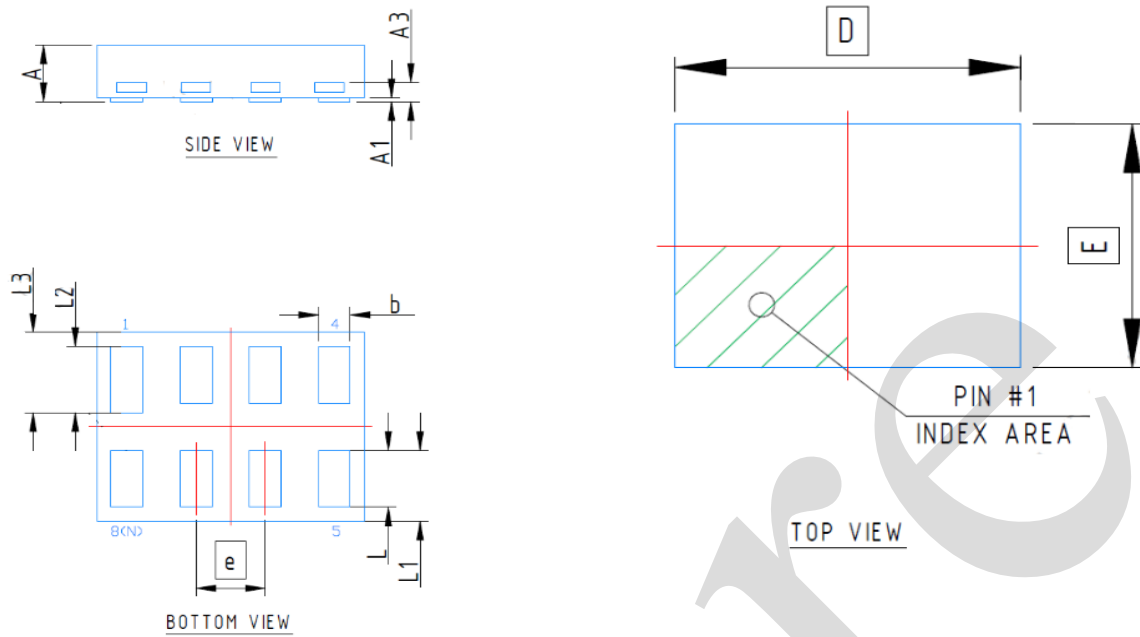

Symbol	Dimensions (mm)	
	Min.	Max.
A	0.28	0.32
A1	0.00	0.05
A3	0.10	
b	0.11	0.21
D	1.35	
E	1.00	
e	0.35	
L	0.25	0.35
L1	0.275	0.475
L2	0.30	0.40
L3	0.325	0.525



## 6.6. QFN10

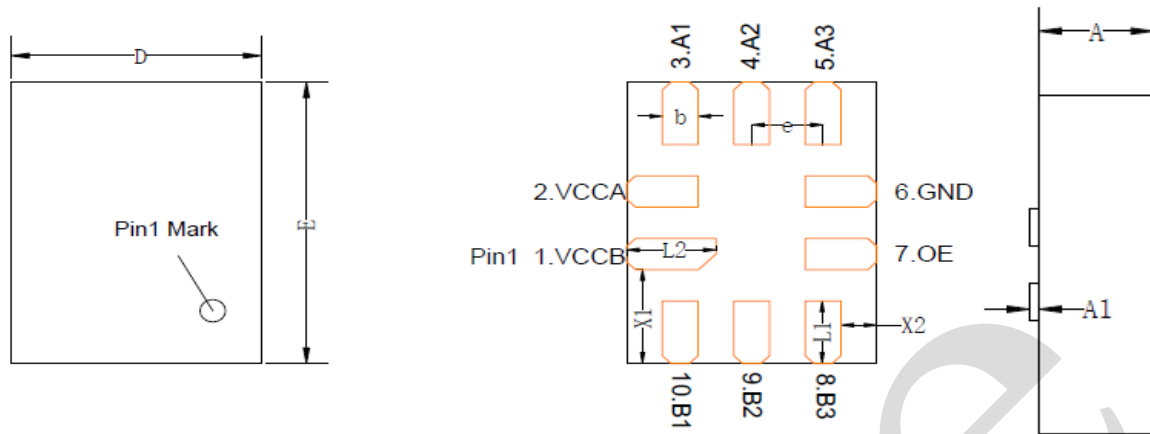

Symbol	Dimensions (mm)	
	Min.	Max.
A	0.45	0.55
A1	0.03	
D	1.30	1.50
E	1.70	1.90
b	0.15	0.25
L1	0.35	0.45
L2	0.45	0.55
e	0.40	
X1	0.55	0.65
X2	0.15	0.25



## 6.7、SOP14

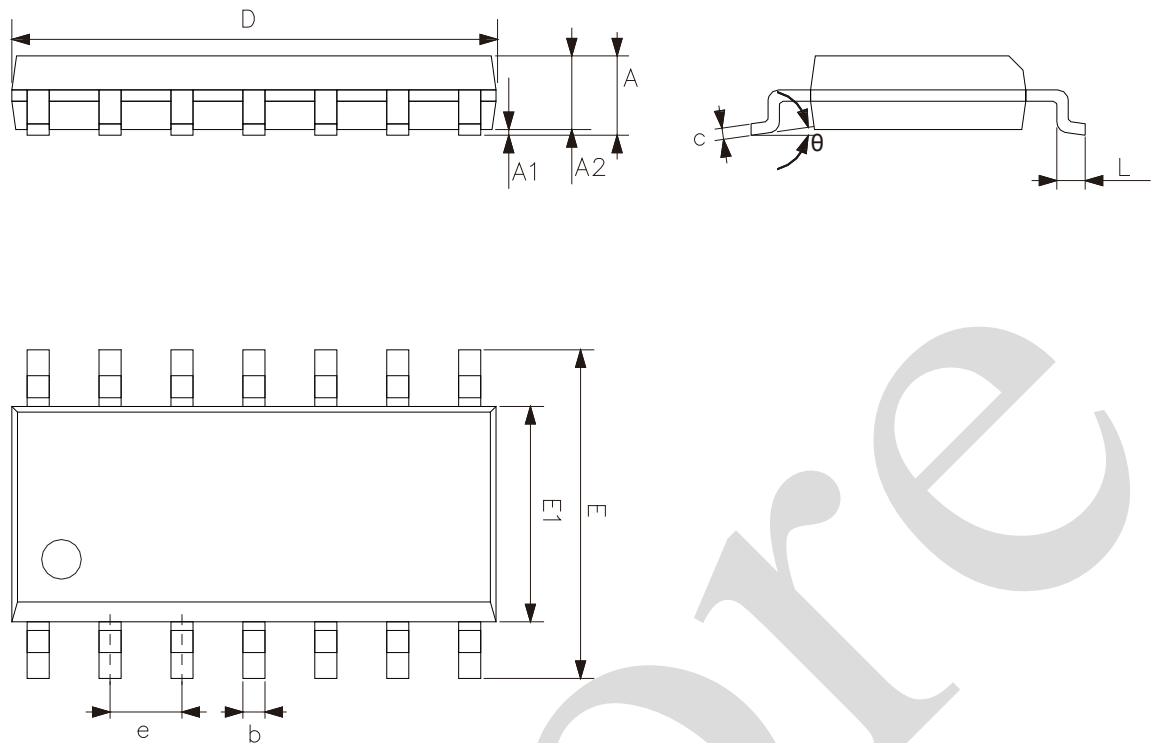

Symbol	Dimensions (mm)	
	Min.	Max.
A	1.50	1.75
A1	0.05	0.25
A2	1.30	-
b	0.33	0.50
c	0.19	0.25
D	8.43	8.76
E	5.80	6.25
E1	3.75	4.00
e	1.27	
L	0.40	0.89
$\theta$	0°	8°



## 6.8、TSSOP14

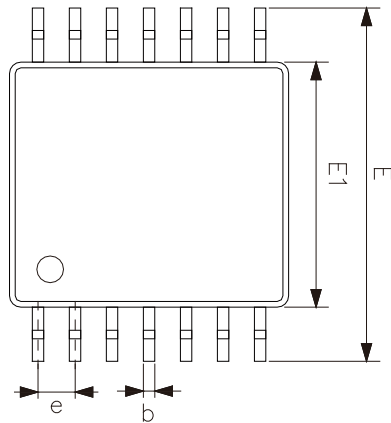
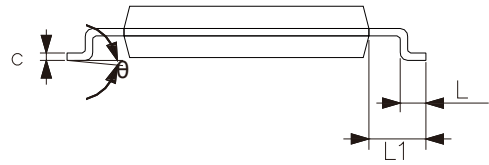
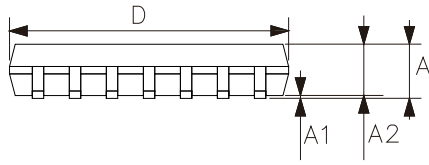

Symbol	Dimensions (mm)	
	Min.	Max.
A	-	1.20
A1	0.05	0.15
A2	0.80	1.05
b	0.19	0.30
c	0.09	0.20
D	4.90	5.10
E1	4.30	4.50
E	6.20	6.60
e	0.65	
L	0.45	0.75
L1	1.00	
$\theta$	0°	8°



## 6.9、TSSOP20

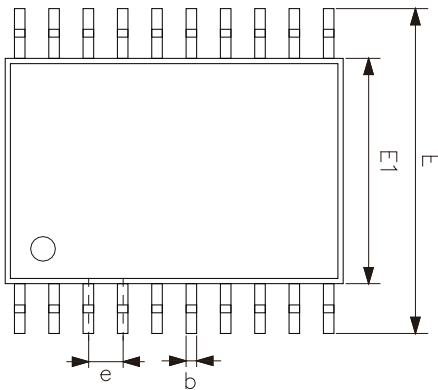
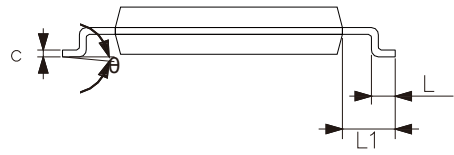
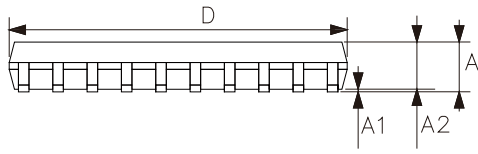

Symbol	Dimensions (mm)	
	Min.	Max.
A	-	1.20
A1	0.05	0.15
A2	0.80	1.05
b	0.19	0.30
c	0.09	0.20
D	6.40	6.60
E1	4.30	4.50
E	6.20	6.60
e	0.65	
L	0.45	0.75
L1	1.00	
$\theta$	0°	8°



## 7、 Statements And Notes

### 7.1、 The name and content of Hazardous substances or Elements in the product

Part name	Hazardous substances or Elements									
	Lead and lead compounds	Mercury and mercury compounds	Cadmium and cadmium compounds	Hexavalent chromium compounds	Polybrominated biphenyls	Polybrominated biphenyl ethers	Dibutyl phthalate	Butylbenzyl phthalate	Di-2-ethylhexyl phthalate	Diisobutyl phthalate
Lead frame	○	○	○	○	○	○	○	○	○	○
Plastic resin	○	○	○	○	○	○	○	○	○	○
Chip	○	○	○	○	○	○	○	○	○	○
The lead	○	○	○	○	○	○	○	○	○	○
Plastic sheet installed	○	○	○	○	○	○	○	○	○	○
explanation	○: Indicates that the content of hazardous substances or elements in the detection limit of the following the SJ/T11363-2006 standard. ×: Indicates that the content of hazardous substances or elements exceeding the SJ/T11363-2006 Standard limit requirements.									

### 7.2、 Notes

Recommended carefully reading this information before the use of this product;

The information in this document are subject to change without notice;

This information is using to the reference only, the company is not responsible for any loss;

The company is not responsible for the any infringement of the third party patents or other rights of the responsibility.